



ISOFLUX ™

The ultrasonic meter

USER MANUAL



IFX-P210

Portable Ultrasonic Flowmeter



Portable_Flow_Meter_IFX-P210_EN_2017_July_Rev.01

ISOIL 
INDUSTRIA

IFX-P210

Operating Instructions

Index

	Page
1 Safety instructions, legal requirements	4
1.1 Symbols used in these operating instructions.....	4
1.2 Safety instructions	5
1.3 Legislative requirements	5
2 Introduction	6
2.1 How to order	7
3 Installation	8
3.1 Unpacking and storage	8
3.1.1 Unpacking	8
3.1.2 Storage.....	8
3.1.3 Identification of components.....	8
3.2 Clamp-on sensor installation	8
3.3 Installation location	10
3.4 Pipe preparation.....	12
3.5 Clamp-on sensor mounting configurations and distance.....	12
3.6 Flowmeter installation	14
3.6.1 Outline dimensions.....	14
3.7 Clamp-on sensor mounting.....	15
3.7.1 Sensor pipe mounting configurations.....	16
3.7.2 Acoustic gel.....	16
3.7.3 Correct positioning of the sensors	16
3.7.4 Sensor mounting with fixtures and chains	17
4 Operation	18
4.1 Switching On/Off	18
4.2 Battery charging	18
4.3 Keypad and display	20
4.3.1 Keypad key functions.....	20
4.3.2 Display functions	22
4.4 Quick setup wizard	23
4.5 Measurements.....	26
4.5.1 Main process value (PV) display	26
4.5.2 Diagnostic displays	27
4.5.3 Totalisers	27

4.5.4	Dual PV display (multi-channel meters).....	27
4.5.5	Datalogger	28
5	Commissioning	28
5.1	Menu structure.....	28
5.2	Diagnostics	33
5.3	Display settings	33
5.3.1	Main PV	33
5.4	Output configuration	34
5.4.1	Serial interface	34
5.5	Inputs/Outputs	34
5.5.1	Modbus RTU.....	34
5.5.2	HART compatible output	35
5.5.3	Analogue current output 0/4 ... 20 mA.....	35
5.5.4	Analogue voltage output 0 – 10 v	35
5.5.5	Analogue frequency output (passive).....	36
5.5.6	Digital open collector output.....	36
5.5.7	Digital relay output	36
5.5.8	Analogue current input 0/4 ... 20 mA.....	37
5.6	Sound velocity measurement (SVM)	37
5.7	Wall thickness measurement (WTM).....	37
5.7.1	Wall Thickness Gauge (WTG) Wizard	38
5.8	Scope function	38
6	Maintenance.....	39
6.1	Service/Repair	39
7	Troubleshooting.....	39
7.1	Data download difficulties.....	41
8	Technical data	42
9	Specification.....	48
10	CE Declaration of Conformity	50

1 Safety instructions, legal requirements

1.1 Symbols used in these operating instructions



Danger

This symbol represents an immediate hazardous situation which could result in a serious **injury, death** or **damage to the equipment**. Where this symbol is shown, do not use the equipment further unless you have fully understood the nature of the hazard and have taken the required precautions.



Attention

This symbol indicates important instructions which should be respected in order to avoid damaging or destroying the equipment. Follow the precautions given in these instructions to avoid the hazard. Call our service team if necessary.



Call service

Where this symbol is shown call our service team for advice if necessary.



Note

This symbol indicates a note or detailed set-up tip.



Information point.



Operator keys are printed in bold typeface and placed in pointed brackets.

1.2 Safety instructions

- Do not install, operate or maintain this flowmeter without reading, understanding and following these operating instructions, otherwise injury or damage may result.
- Study these operating instructions carefully before the installation of the equipment and keep them for future reference.
- Observe all warnings, notes and instructions as marked on the packaging, on the equipment, and detailed in the operating instructions.
- Do not use the instrument under wet conditions with the battery cover removed or opened.
- Follow the unpacking, storage and preservation instructions to avoid damage to the equipment.
- Install the equipment and cabling securely and safely according to the relevant regulations.
- If the product does not operate normally, please refer to the service and troubleshooting instructions, or contact Isoil Industria for help.

1.3 Legislative requirements

CE marking

The flowmeter is designed to meet the safety requirements in accordance with sound engineering practice. It has been tested and has left the factory in a condition in which it is safe to operate. The equipment is in conformity with the statutory requirements of the EC directive and complies with applicable regulations and standards for electrical safety EN 61010 and electro-magnetic compatibility EN 61326. A CE Declaration of Conformity has been issued in that respect, a copy of which can be found in the Appendix of these operating instructions.

WEEE Directive

The Waste Electrical and Electronic Equipment Directive (WEEE Directive) aims to minimise the impact of electrical and electronic goods on the environment by increasing re-use and recycling and by reducing the amount of WEEE going to landfill. It seeks to achieve this by making producers responsible for financing the collection, treatment, and recovery of waste electrical equipment, and by obliging distributors to allow consumers to return their waste equipment free of charge.

RoHS Directive

All products manufactured by ISOIL INDUSTRIA are compliant with the relevant aspects of the RoHS Directive.

2 Introduction

Clamp-on transit-time flowmeter

The IFX-P 210 is a portable, battery operated ultrasonic flowmeter employing clamp-on sensors for the measurement of liquids in full, enclosed pipes. Flow measurements can be undertaken without interruption of the process or interference with the integrity of the pipeline. The clamp-on sensors are attached to the outside of the pipes. The IFX-P 210 uses ultrasonic signals for the measurement of the flow, employing the transit-time method.

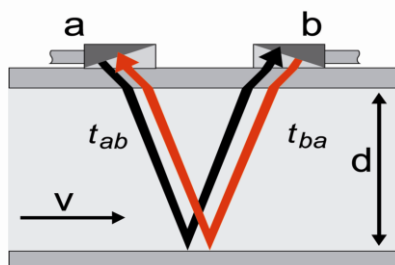

Illustration 1: Clamp-on ultrasonic sensor configuration

Measuring principle

Ultrasonic signals are emitted by a transducer installed on a pipe and received by a second transducer. These signals are emitted alternately in the direction of flow and against it. Because the medium is flowing, the transit time of the sound signals propagating in the direction of flow is shorter than the transit time of the signal propagating against the direction of flow. The transit-time difference ΔT is measured and allows the determination of the average flow velocity along the path of acoustic propagation. A profile correction is then performed to obtain the average flow velocity over the cross-sectional area of the pipe, which is proportional to the volumetric flow rate.

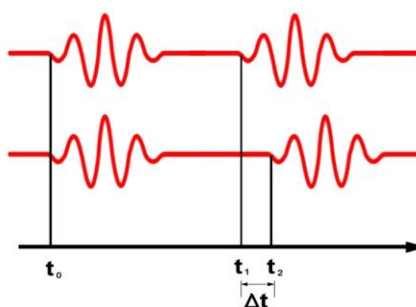

Illustration 2: Transit-time measuring principle

2.1 How to order

How to order	
IFX-P210 Portable Clamp-on Ultrasonic flow meter	
Model code	Description
IFX-P210-	
1	Portable ultrasonic flowmeter with LCD display, data logger, Interface SW and download cable, integral rechargeable battery LiFePO4 12,4 Ah - including battery charger with connector and Europe mains adapter Portable Flow meter - Suitable for measuring campains
2	Portable ultrasonic flowmeter with LCD display, data logger, Interface SW and download cable integral rechargeable battery LiFePO4 24,8 Ah - including battery charger with connector and Europe mains adapter
3	Portable ultrasonic flowmeter with LCD display, data logger, Interface SW and download cable integral rechargeable battery LiFePO4 37,2 Ah - including battery charger with connector and Europe mains adapter
	I/O Modular cards for IFX-P210 (max 2 selectable if Modbus or Hart are not used)
A	IOMOD_Current output board active, 0/4 ... 20 mA
B	IOMOD_Current output board passive, 0/4 ... 20 mA
C	IOMOD_Voltage output board 0 ... 10 V
D	IOMOD_Relay output board
E	IOMOD_Open-Collector output board - Pulse
F	IOMOD_Frequency output board, 0 ... 10 kHz
G	IOMOD_Modbus RTU protocol output board (if selected cannot be used with any other output)
I	IOMOD_HART compatible output board, 4 ... 20 mA (if selected cannot be used with any other output)
L	IOMOD_Current input board active, 0/4 ... 20 mA
Z	Without process output
	Clamp-on sensor for IFX-P210
1	Clamp-on ultrasonic transducer pair type K1N , -30 ... 130 °C, with IP67 connector and 4 meters cable. DN50 to DN3000
	Mounting Accessories
A	Without
B	Clips and chain 2 m lenght (pair) - up to DN600 - other lenghts on request
C	Magnetic mounting arrangement for K1 sensors, ruler and mounting clamps allow quick and easy installation on pipes, 2 m chain included for non-magnetic pipework
	Wall thickness gauge
1	Without
2	Integral wall thickness gauge with probe and cable, to be used on IFX-P210. Temperature -20 ... 200 °C
3	External wall thickness gauge
	Acoustical Paste / Accessory
A	Without Acoustical paste
B	Acoustical paste Pack of 100 ml Suitable for temperature -30 +130 °C
C	Output connector cable with bare wires, required when I/O(card are supplied
	Example of order:
IFX-P210-1Z1B2B	Portable meter with case, without any process output, K1N sensors , Clips and chains, integral thickness gauge and Acoustical paste



3 Installation

3.1 Unpacking and storage

3.1.1 Unpacking

Care should be taken when opening the box containing the flowmeter, any markings or warnings shown on the packaging should be observed prior to opening. The following steps should then be taken:

- Unpack the flowmeter in a dry area;
- The flowmeter should be handled with care and not left in an area where it could be subject to physical shocks;
- If using a knife to remove packaging care should be taken not to damage the flowmeter or cables;
- The flowmeter package and contents should be checked against the delivery note supplied and any missing items reported immediately;
- The flowmeter package and contents should be checked for signs of damage during transport and any problems reported immediately;
- The vendor accepts no responsibility for damage or injury caused during the unpacking of the instrumentation supplied;
- Excess packing materials should be either recycled or disposed of in a suitable way.

3.1.2 Storage

If storage is necessary, the flowmeter and sensors should be stored:

- in a secure location;
- away from water and harsh environmental conditions;
- in such a way, as to avoid damage;
- small items should be kept together in the bags and small plastic boxes provided to avoid loss.

3.1.3 Identification of components

The following items are typically supplied (please refer to your delivery note for a detailed description):

- IFX-P 210 portable flowmeter
- Fuse (removed for transport)
- Clamp-on sensors
- Sensor mounting accessories (optional)
- Acoustical paste (optional)
- Operating instructions
- Calibration certificate
- Process output terminal box (optional)

3.2 Clamp-on sensor installation

The correct selection of the sensor location is crucial for achieving reliable measurements and a high accuracy. Measurement must take place on a pipe in which sound can propagate (see Acoustic Propagation) and in which a rotationally symmetrical flow profile is fully developed (see Straight Pipe Lengths).

The correct positioning of the transducers is an essential condition for error-free measurements. It guarantees that the sound signal will be received under optimal conditions and evaluated correctly. Because of the variety of applications and the different factors influencing the measurement, there can be no standard solution for the positioning of the transducers.

The correct position of the transducers will be influenced by the following factors:

- diameter, material, lining, wall thickness and general condition of the pipe;
- the medium flowing in the pipe;
- and the presence of gas bubbles and solid particles in the medium.

Check that the temperature at the selected location is within the operating temperature range of the transducers (see technical specification in the Appendix).

Acoustic propagation Acoustic propagation is given when the flowmeter is able to receive sufficient signal from the transmitted ultrasonic pulses. The signals are attenuated in the pipe material, the medium and at each of the interfaces and reflections. External and internal pipe corrosion, solid particles and gas content in the medium do heavily contribute to signal attenuation.

Straight pipe lengths Sufficient straight lengths of pipe on the inlet and outlet of the measuring location guarantee an axi-symmetrical flow profile in the pipe for good measurement accuracy. If no sufficient straight lengths of pipe are available for your application, measurements are still obtainable but the uncertainty of the measurement can be compromised.

3.3 Installation location

Select an installation location following the recommendations in Table 1 and try to avoid measuring:



- in the vicinity of deformations and defects of the pipe,
- near welding seams,
- where deposits could be building up in the pipe.

For a horizontal pipe:

Select a location where the transducers can be mounted on the side of the pipe, so that the sound waves emitted by the transducers propagate horizontally in the pipe. In this way, the solid particles deposited on the bottom of the pipe and the gas pockets developing at the top will not influence the propagation of the signal.



For a free inlet or outlet pipe section:

Select the measuring point at a location where the pipe cannot run empty.

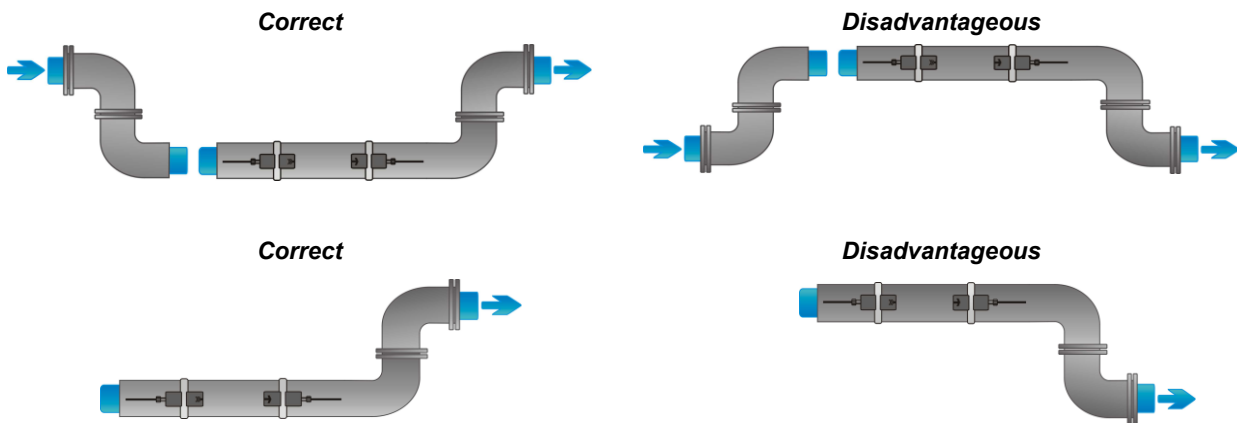

For a vertical pipe:

Select the measuring point at a location where the liquid flows upward to ensure that the pipe is completely filled.

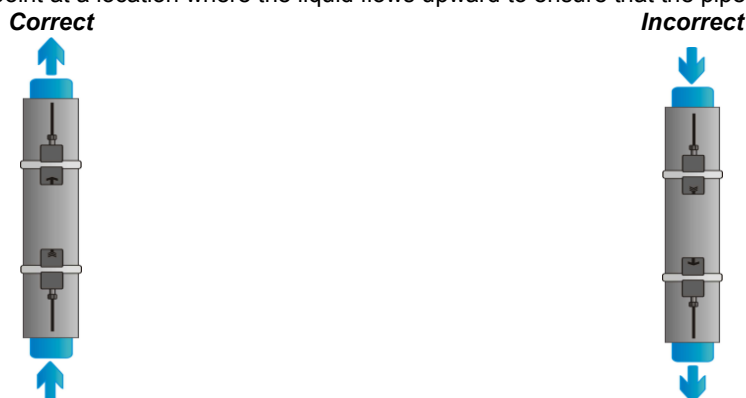
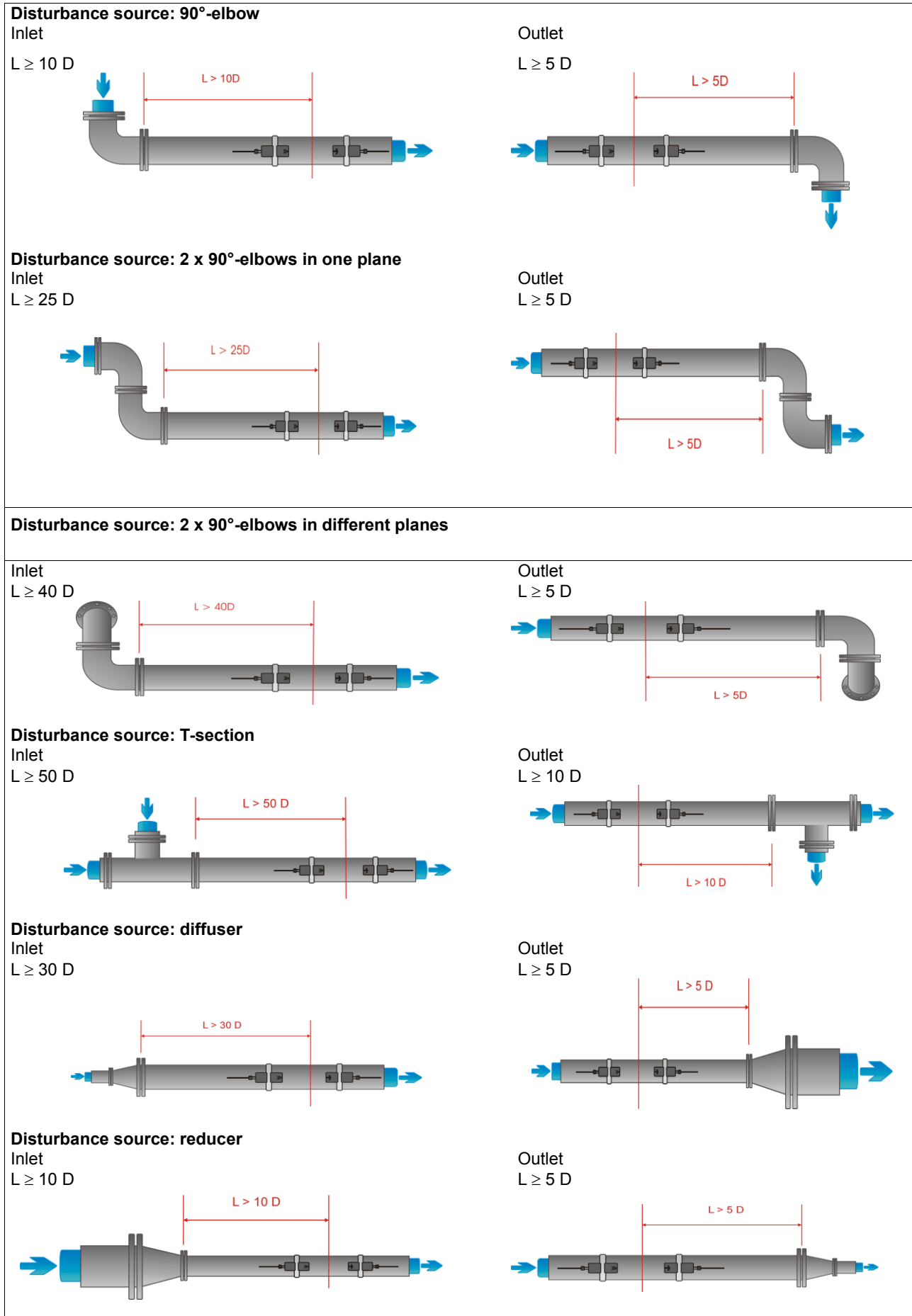

Table 1: Recommendations for sensor mounting location



Look for a sensor installation location with sufficient straight pipe to obtain accurate measurements. Please refer to Table 2 as a guideline for recommended distances from disturbance sources.



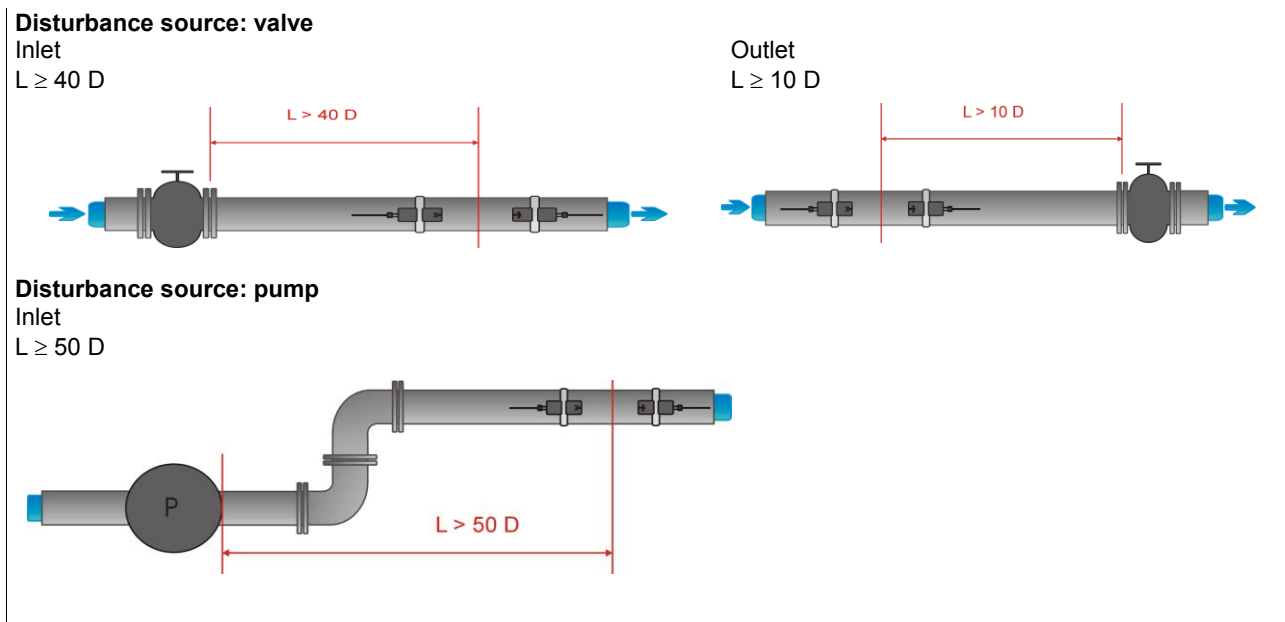

Table 2: Recommended distances from disturbance sources

3.4 Pipe preparation



- Clean dirt and dust from around the area of the pipework where the sensors are to be placed;
- Remove loose paint and rust with a wire brush or file.

Firmly bonded paint does not necessarily need to be removed provided the flowmeter diagnostics indicate sufficient signal strength.

3.5 Clamp-on sensor mounting configurations and distance

Reflection Mode

The most common clamp-on sensor mounting configuration is the Reflection Mode, sometimes known as V-Mode (see Illustration 3, sketch (1)). Here, the ultrasonic signal passes twice through the medium (2 signal passes). The Reflection Mode is the most convenient mounting method as the transducer separation distance can be measured easily and the sensors can be accurately aligned. This method should be used whenever possible.

Diagonal Mode

An alternative mounting configuration (Illustration 3, sketch (3)) is the Diagonal mode (Z-Mode). The signals travel only once through the pipe. This method is often used for larger pipes where greater signal attenuation might occur.

Further variation of the Reflection and the Diagonal Modes are possible by altering the number of passes through the pipe. Any even number of passes will require mounting the sensors on the same side of the pipe, while with an odd number of passes, the sensors must be mounted on opposite sides of the pipe. Commonly, for very small pipes, sensor mounting configurations such as 4 passes (W-mode) or 3 passes (N-mode) are used (Illustration 3, sketch (2)).

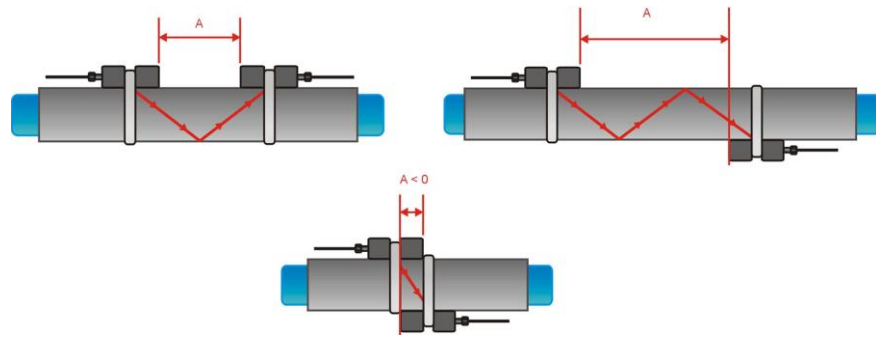

Illustration 3: Clamp-on sensor mounting configurations and sensor spacing

**Transducer
separation distance**

The transducer separation distance A is measured from the inside edges of the sensor heads as shown in illustration 3. It is automatically calculated by the flowmeter based on the parameter entries for pipe outside diameter, wall thickness, lining material and thickness, medium, process temperature, the sensor type and the selected number of signal passes.

A negative separation distance $A < 0$ can occur for mounting configurations on small pipes where diagonal mode operation has been selected (see Illustration 3, sketch (3)). Negative separation distances may be suggested for reflection mode installations, but are not possible. In these cases, use diagonal mode or a larger number of passes.

3.6 Flowmeter installation

3.6.1 Outline dimensions

The IFX-P 210 is a portable, battery operated device with the following outline dimensions.

Flowmeter outline dimensions

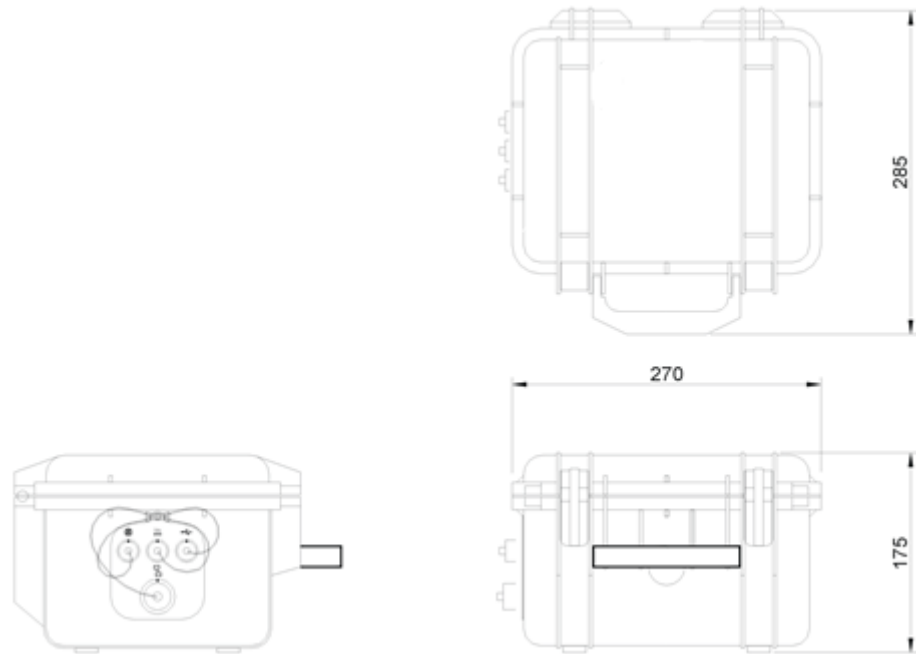

K1 type transducer

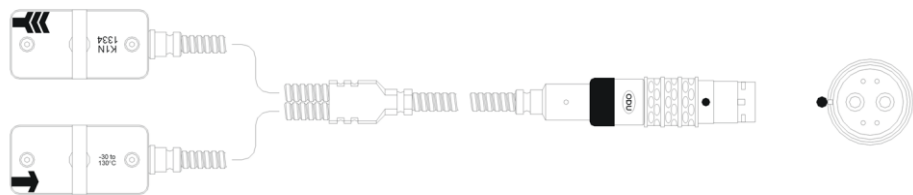

3.6.2 Electrical connections

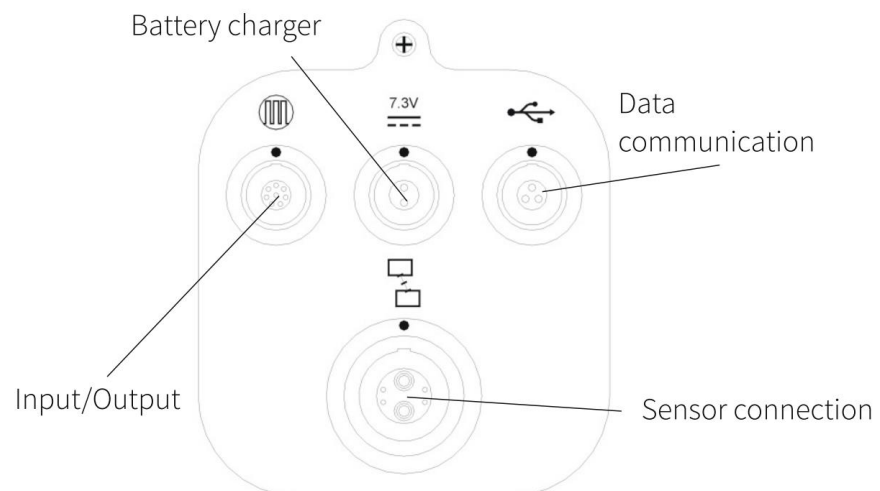

3.7 Clamp-on sensor mounting

Before the sensors can be mounted

- the installation location should have been determined,
- a sensor mounting method should be chosen,
- the flowmeter batteries must be sufficiently charged,
- the sensors must be connected to the transmitter.

Depending on which sensor mounting method is being used, the clamp on sensors are either mounted on the same side of the pipe (Reflection Mode) or on opposite sides of the pipe (Diagonal Mode – See Section 2.5).



Illustration 4: Sensor mounting with clips and chains

3.7.1 Sensor pipe mounting configurations

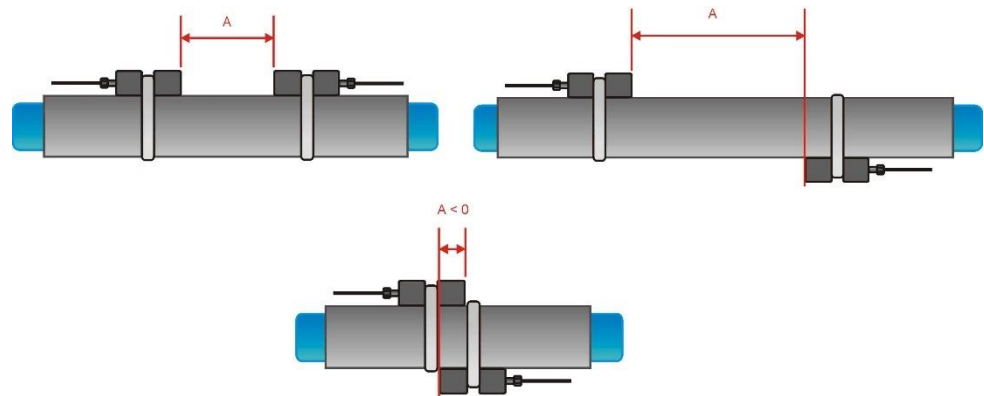

Illustration 5: Sensor pipe mounting configurations

3.7.2 Acoustic gel



In order to obtain acoustical contact between the pipe and the sensors, apply a bead of acoustic coupling gel lengthwise down the centre of the contact area of the sensors.

3.7.3 Correct positioning of the sensors



Mount the transducer pair so that the front edges of the sensors (opposite the cable entry) face each other.

There is a different engraving on the top of each transducer. The transducers are mounted correctly if the engravings on the two transducers form an arrow. The transducer cables should point in opposite directions.

Later, the arrow, in conjunction with the indicated measured value, will help to determine the direction of flow.

The sensor separation distance is automatically calculated by the flowmeter based on the parameter entries for pipe outside diameter, wall thickness, lining material and thickness, medium, process temperature, the sensor type and the selected number of signal passes. The sensor positioning screen (above, and Section 3.3) allows fine adjustment of the sensor location.

3.7.4 Sensor mounting with fixtures and chains



Illustration 6: Sensor mounting with fixtures and chains

- Insert the retaining clip into the groove on the top of the transducer and secure it using the screw knob.
- Apply some acoustic coupling component to the contact surface of the transducer.
- Place the transducer on the side of the pipe or alternatively up to 45 degrees from the horizontal plane through the pipe.

This is advisable to establish the best acoustic contact since on top of the pipe air pockets could develop and deposits could accumulate at the bottom of the pipe.



- Take the spring end of the chain in one hand and insert the last ball element in the vertical slot of the retaining clip. Mount the chain around the pipe.
- Pull the chain firmly around the pipe and fasten it in the lateral slot of the retaining clip. There should be no air pockets between the transducer surface and the pipe wall.
- Mount the second transducer the same way.
- Using a measuring tape, adjust the sensor separation distance as suggested by the flowmeter. When the sensor positioning screen (Section 3.3) is displayed, the middle bar allows fine adjustment of the sensor location.



Illustration 7: Sensor mounting with fixtures and chains (retaining clip)

4 Operation

4.1 Switching On/Off

The flowmeter is switched on by holding the <ON> key for more than 2 seconds continuously. Equally it can be switched off by pressing the <OFF> key for more than 2 seconds.

4.2 Battery charging

The internal batteries can be recharged with the external battery charger supplied.



Connect the battery charger to the charging socket of the flowmeter and to the mains supply 100 ... 240 VAC, 50/60 Hz.

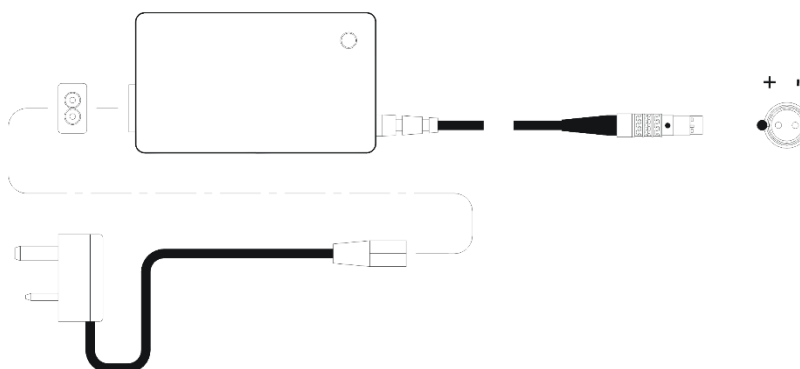

Illustration 8: Battery charging

The red mark on the plug aligns with the mark on the socket. Remove plug by sliding the outer casing away from the socket to release the latch.

Charging Status: **LED COLOUR ON CHARGER DURING THE CHARGING**

	Orange - Battery empty
	Yellow - Battery partially empty
	Green - Battery fully charged



After **EACH** full battery charge (green led), the battery status **must** be set as “Battery Full” by:

Main Menu / Systems / Settings / Battery / Battery Full

Once the flowmeter is told of a fully charge the battery icon, and internal calculations are reset, allowing the proper functioning of the flowmeter and battery icon.

From empty batteries, the complete charging of the flowmeter will be achieved in:

- One Battery: 4 hours
- Two Batteries: 8 hours







- Three Batteries: 12 hours

During the discharging of the battery, the remaining battery charge (%) is available in the Diagnostic menu as well as it is represented by the relevant display icon. The battery charge level is not updated during the charging.

4.3 Keypad and display



4.3.1 Keypad key functions

Key	Main function	Secondary function
	Character entry: 1 (1 short key stroke) , (2 short key strokes) . (3 short key strokes) _ (4 short key strokes)	Show NEXT available item
	Character entry: A B C 2 /	QON = Start totalizer function
	Character entry: D E F 3 ?	Show next Display
	Character entry: G H I 4 <	Q- = Reset negative total value
	Character entry: J K L 5 >	
	Character entry: M N O 6 \$	Q+ = Reset positive total value
	Character entry: P Q R S 7	Toggle MU ltiple X er (where multi-channel functions are provided)



















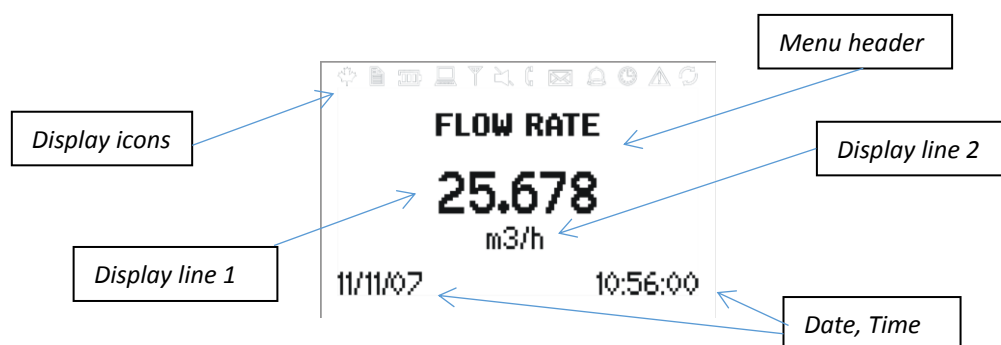

	Character entry: T U V 8 *	Q _{OFF} = Stop totaliser function
	Character entry: W X Y Z 9	
	Move menu/list selection item UP	Character backspace clear
	Character entry: . (decimal point)	Switch LCD backlight on/off
	Character entry: 0 Space character + = #	
	Move menu/list selection item DOWN	Character entry : - (minus sign)
	ESC ape menu item	Abort entry without saving
	ENTER menu item	Confirm entry with saving

Table 3: Keyboard function

4.3.2 Display functions







Display icon	Function
	On Icon not used Off Icon not used
	On Datalogger recording Off Datalogger switched off
	On 1 segment = 33% battery power available 2 segments = 66% battery power available 3 segments = 100% battery power available Off < 5% battery power available
	On LCD backlight switched on Off LCD backlight switched off
	On I/O processor error Off I/O processor functioning correctly
	On Without strike-through: Speaker on Off with strike-through: Speaker off
	On Poor sensor coupling, low SNR Off Sensor coupling OK
	On Icon not used Off Icon not used
	On Icon not used Off Icon not used
	On RTC operating Off RTC failure
	On Error recorded in error log Off No error detected
	On Serial output switched on Off Serial output switched off
"L", "T" or "LT"	Displays whether flow is laminar, turbulent or mixed

4.4 Quick setup wizard

Quick start wizard

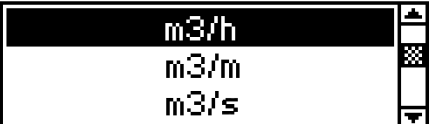
The quick setup wizard allows for a speedy setup of the most important parameters in order to achieve successful measurements in the shortest possible time:

Display screen	Operation
<p style="text-align: center;">MAIN MENU</p> 	<p>The main menu is displayed after first power on and the boot-up sequence.</p> <p>Use <UP> and <DOWN> cursor keys to select Quick start. Confirm by pressing <ENTER>.</p> 
<p style="text-align: center;">SAVER MODE</p> <p>Yes</p> <p>No</p>	<p>Saver Mode Yes/No</p> <p>Yes : Flowmeter will wake every “Measurement Period” (see below), take a measurement, then switch into low power mode.</p> <p>No : Meter will remain powered, and take a measurement each “Measurement Period”.</p>
<p style="text-align: center;">MEAS PERIOD</p> <p style="text-align: center;">1</p> <p style="text-align: center;">minutes</p>	<p>Measurement period - Enter period of measurement in seconds (default 1s), or in minutes (default 1 minute) if Saver Mode has been selected.</p> <p>If sensors are recognised, the serial number will be shown. If not recognised or not connected, they may be selected from a list.</p>
<p style="text-align: center;">MIDDLE UNITS</p> 	<p>Select units of measurement using cursor keys and pressing <ENTER>.</p>
<p style="text-align: center;">PIPE MATERIAL</p> 	<p>Choose pipe material using cursor keys and pressing <ENTER>.</p> <p>Selecting “User” will allow manual entry of pipe sound speed.</p>

<p>OUTSIDE DIAMETER</p> <p style="text-align: center;">76.1 mm</p>	<p>Enter outside pipe diameter using alphanumeric keys and confirm by pressing <ENTER>.</p> <p>Use key <UP> as character backspace clear to correct for data entry errors.</p> <p>If 0 is entered, an additional screen appears that allows entering the pipe circumference.</p>
<p>WALL THICKNESS</p> <p style="text-align: center;">3.4 mm</p>	<p>Enter pipe wall thickness using alphanumeric keys and confirm by pressing <ENTER>.</p> <p>Use key <UP> as character backspace clear to correct for data entry errors.</p>
<p>INNER DIAMETER</p> <p style="text-align: center;">69.3 mm</p>	<p>Enter inner pipe diameter using alphanumeric keys and confirm by pressing <ENTER>.</p> <p>The value that appears here will have been calculated from the entered Outside Diameter (or Circumference) and Wall thickness. Entering a new value here will recalculate the Outside Diameter.</p>
<p>FLUID</p> <div style="border: 1px solid black; padding: 5px;"> <p style="text-align: center;">Water</p> <p style="text-align: center;">Saltwater</p> <p style="text-align: center;">Acetone</p> </div>	<p>Select fluid using cursor keys.</p> <p>Confirm by pressing <ENTER>.</p> <p>Selecting "User" will allow manual entry of density, viscosity and medium sound speed.</p>
<p>TEMPERATURE</p> <p style="text-align: center;">20.0 C</p>	<p>Enter process temperature using alphanumeric keys and confirm by pressing <ENTER>.</p> <p>Use key <UP> as character backspace clear to correct for data entry errors.</p>
<p>LINER MATERIAL</p> <div style="border: 1px solid black; padding: 5px;"> <p style="text-align: center;">None</p> <p style="text-align: center;">Epoxy</p> <p style="text-align: center;">Rubber</p> </div>	<p>Select pipe lining material using cursor keys.</p> <p>Confirm by pressing <ENTER>.</p> <p>Selecting "User" will allow manual entry of liner sound speed.</p>
<p>PASSES</p> <div style="border: 1px solid black; padding: 5px;"> <p style="text-align: center;">Auto</p> <p style="text-align: center;">1</p> <p style="text-align: center;">2</p> </div>	<p>Select transducer configuration (number of passes) using cursor keys.</p> <p>Auto Automatically recommended</p> <p>1 1 pass, diagonal mode</p> <p>2 2 passes, reflection mode</p> <p>3 3 passes, diagonal mode</p> <p>4 4 passes, reflection mode</p> <p>..etc.</p> <p>Confirm by pressing <ENTER>.</p>



<p style="text-align: center;">QUICK START</p> <p>Setup Wizard CH2 Stored Setup Start Measurement Scope</p> 	<p>Use cursor keys to select Start Measurement. Confirm by pressing <ENTER>.</p> <p>If sensors are recognised, the serial number will be shown. If not recognised or not connected, they may be selected from a list.</p>
<p style="text-align: center;">CHNL1 SENSOR</p> <p>Spacing 110.5 mm Using 2 passes Signal 26 dB</p> 	<p>Sensor placement screen: Mount transducers with suggested spacing and use middle bar for fine adjustment of position (central position is desired). Observe signal-to-noise (upper bar) and quality (lower bar). These should be of identical length.</p> <p>Confirm by pressing <ENTER> to obtain measurements.</p>
<p style="text-align: center;">CHNL-1</p> <p style="text-align: center;">25.678 m3/h</p> <p>11/11/07 10:56:00</p>	<p>Success!</p>

Table 4: Quick Start wizard

4.5 Measurements

4.5.1 Main process value (PV) display

Measurement is started using the Quick Setup Wizard. Once all the parameters are programmed, any subsequent power-on sequences will bring up the main PV display immediately.

Display screen	Operation
<pre> CHNL-1 25.678 m3/h 11/11/07 10:56:00 </pre>	<p>The main process value can be changed using the menu structure.</p> <p>Press <ESC> at any time to return to the main menu.</p> <p>Change to the totalizer display, the 3-line display, and dual display mode by pressing <NEXT>, or to the diagnostic screens by pressing <DISP>.</p>

3-line display format

Display screen	Operation
<pre> CHNL-1 - 0.0 m3 25.678 m3/h 1.370 m/s 11/11/07 10:56:00 </pre>	<p>The three-line display screen is configurable to show flow, totalizers and diagnostic functions.</p> <p>Change to diagnostic displays by pressing <DISP> and to totalizer and dual mode screens by pressing <NEXT>.</p> <p>Cycle through screens using <NEXT>.</p> <p>Cycle through available flow channels using <MUX>.</p>

4.5.2 Diagnostic displays

Diagnostic screens

Display screen	Operation
<p style="text-align: center;">DIAGNOSTIC 1</p> <p style="text-align: center;">55.2 Gain 20.5 Signal -10.0 Noise</p> <p>11/11/07 10:56:00</p>	<p>Line 1 shows the amplifier gain.</p> <p>Line 2 displays the signal strength.</p> <p>Line 3 indicates the noise.</p> <p>Change to more diagnostic displays by pressing <NEXT>.</p>

4.5.3 Totalisers

The totaliser displays will only be shown when the totalisers are activated.

Totalisers

Display screen	Operation
<p style="text-align: center;">CHNL-1</p> <p style="text-align: center;">- 1.3 m3 25.678 m3/h 37.3 m3</p> <p>11/11/07 10:56:00</p>	<p>The flow totalizer may be assigned to lines in the three line display, the datalogger or process outputs. They can be started or reset by pressing <QON>.</p> <p>Pressing <Q+> resets the total accumulated flow in positive flow direction. Pressing <Q-> resets the total accumulated flow in negative flow direction.</p> <p>The totalizers can be stopped by activating <QOFF>. Pressing <QON> again will reset to zero.</p> <p>Change to other displays or revert to the three line display screen without resetting by pressing <DISP> or <NEXT>.</p>

4.5.4 Dual PV display (multi-channel meters)

Display screen	Operation
<p style="text-align: center;">DUAL-1</p> <p style="text-align: center;">37.3 m3/h 1.370</p> <p>11/11/07 10:56:00</p>	<p>Line 1 shows the PV on the selected channel.</p> <p>Line 2 shows the selected units.</p> <p>Line 3 shows the PV on the other channel (in its selected units)</p> <p>Change to diagnostic displays by pressing <DISP> and to totalizer and main PV screens by pressing <NEXT>.</p> <p>Cycle through available flow channels using <MUX>.</p>

4.5.5 Datalogger



The datalogger is enabled from the Main Menu, and operates when a non-zero value is entered for the interval.

Items to be logged are selected from the “Selection” screen. “ENTER” selects items, “0” deselects. Up to ten items may be selected.

(Note : If no items are selected the logger will record blank space)

Send logger by serial port to a terminal program by selecting “Log download”.

Clear the logger by selecting “Log Erase”.

Remaining logger space can be seen in the Diagnostic displays.

Logged data can be downloaded, viewed and exported using the Isoflux+ software except when "wrap" mode has been enabled.

5 Commissioning

5.1 Menu structure

Menu structure

Main menu	Menu level 1	Menu level 2	Description/settings
Quick Start			
	Setup Wizard		
		Saver Mode	Select from list ↑↓ (Yes/No)
		Meas. Period	Enter measurement period in minutes (Saver Mode) or seconds (Not saver Mode)
		Sensor type	Indication of sensor type and serial number if automatically detected, otherwise select from list ↑↓ K1N,K1L,K1E,K1Ex,K1P, K4N,K4L,K4E,K4Ex,K4P, K0, M, Q, Special ("Special" allows individual entry of sensor parameters)
		Middle (main displayed) Units	Select from list where available ↑↓ m/s, f/s, in/s, m3/h, m3/min, m3/s, l/h, l/min, l/s, USgal/h, USgal/min, USgal/s, bbl/d, bbl/h, bbl/min, g/s, t/h, kg/h, kg/min, m3, l, Usgal, bbl, g, t, kg, W, kW, MW, J, kJ, MJ, Signal (dB), noise (dB), SNR (dB), C m/s (measured sound speed), CU (housing temperature), K (correction factor), REY (Reynolds number), V (battery voltage) SOS, DEN, KIN, DYN, SHC (sound speed, density, kinematic viscosity, dynamic viscosity, Specific Heat Capacity from inputs/calculation), TEMP (specified or measured fluid temperature), PRESS (specified or measured fluid pressure), Tin, Tout (inlet and outlet temperature)
		Pipe material	Select from list ↑↓ Stainless steel, Carbon steel Ductile cast iron, Grey cast iron Copper, Lead PVC, PP, PE, ABS Glass, Cement User (pipe c-speed)
		Pipe c-speed	Only if user pipe material selected 600 ... 6553.5 m/s
		Outside diameter	6 ... 3000 mm
		Wall thickness	0.5 ... 80 mm
		Inner diameter	6 ... 3000 mm
		Fluid	Select from list ↑↓ Water, Salt water Acetone, Alcohol, Ammonia

			Carbon Tet (carbon tetrachloride) Ethanol, Ethyl alcohol, Ethyl ether Ethylene glycol, Glycol/water 50% Kerosene, Methanol, Methyl alcohol Milk, Naphtha, Car oil Freon R134a, Freon R22 Hydrochloric acid, Sour cream, Sulphuric acid Toluene, Vinyl chloride User (enter kinematic viscosity, density, medium c-speed)
		Kinematic viscosity	<i>Only if user fluid selected</i> 0.001 ... 30000 mm ² /s
		Dynamic viscosity	0.000 ... 30000 mPa.s
		Density	<i>Only if user fluid selected</i> 100 ... 2000 kg/m ³
		Medium c-speed	<i>Only if user fluid selected</i> 100 ... 3500 m/s
		Temperature	-30 ... 300 °C
		Liner Material	<i>Select from list</i> ↑↓ None, Epoxy, Rubber, PVDF, PP, Glass, Cement, User (liner c-speed)
		Liner thickness	<i>Only if lining material selected</i> 1.0 ... 99.0 mm
		Liner c-speed	<i>Only if lining material selected</i> 600 ... 6553.0 m/s
		Passes	<i>Select from list</i> ↑↓ Auto 1...16
	Stored Setup		
		Load	<i>Load from list</i>
		Save	<i>Save to list – use alphanumeric keys to enter name</i>
		Delete	<i>Delete from list</i>
	Start Measurement		
		Sensor type	<i>Indication of sensor type and serial number if automatically detected, otherwise select from list</i> ↑↓ As Setup Wizard
		Sensor frequency	<i>SP1, only for special, unrecognised sensors</i>
		Wedge angle	<i>SP2, only for special, unrecognised sensors</i>
		Wedge c-speed 1	<i>SP3, only for special, unrecognised sensors</i>
		Wedge c-speed 2	<i>SP4, only for special, unrecognised sensors</i>
		Crystal offset	<i>SP5, only for special, unrecognised sensors</i>
		Spacing offset	<i>SP6, only for special, unrecognised sensors</i>
		Zero flow offset	<i>SP7, only for special, unrecognised sensors</i>
		Upstream offset	<i>SP8, only for special, unrecognised sensors</i>
		K factor	<i>Calibration factor (slope)</i>
		Sensor placement	Adjust sensor position
	Scope		
			Displays received acoustic pulse
	WTG Wizard		

		Reference THK	
		Calibrate	
	Meas. Period		
			Change measurement period (Note this will keep the setting in "Saver Mode", so will show minutes if "Yes", seconds if "No".)
Installation			
	Pipe		
		Material	Select from pipe material list ↑↓
		Outside diameter	6 ... 3000 mm
		Wall thickness	0.5 ... 80 mm
		Inner diameter	6 ... 3000 mm
		C-speed	600 ... 6554 m/s (transverse sound speed)
		L-Speed	600 ... 8000 m/s (longitudinal sound speed)
		Circumference	18.8 ... 20420 mm
		Roughness	0.0 ... 10 mm
	Medium		
		Fluid	Select from fluid list ↑↓
		Kinematic viscosity	0.000 ... 30000 mm ² /s
		Dynamic viscosity	0.000 ... 30000 mPa.s
		Density	100 ... 2000 kg/m ³
		C-speed	100 ... 3500 m/s
		Temperature	-30 ... 300 °C
	Lining		
		Material	Select from material list ↑↓
		Thickness	1 ... 99 mm
		C-speed	600 ... 6553 m/s
	Passes		
		Passes	Select from list ↑↓
Display			
		Top Line	Select from unit list ↑↓
		Middle Line	Select from unit list ↑↓
		Bottom Line	Select from unit list ↑↓
		Damping	Reduces fluctuations in the display output 1 ... 255 s
		Metric / Imp	Use metric or imperial units for entered data
In/Output			
		Type	Select from list ↑↓
	I Out		Analogue current output
		Source	Select from list ↑↓ Off Channel 1, Channel 2 Math 1, Math 2 System, Test
		Units	Select from unit list ↑↓
		Min Value	Min. process variable (PV) value that corresponds to 0/4 mA
		Max Value	Max. process variable (PV) value that corresponds to 20 mA

		Damping	<i>Additional smoothing of the current output, the higher the damping factor, 1 ... 255 s</i>
		Span	0-20mA or 4-20mA
		Error	<i>Defines output behaviour in the event of error</i> Select from list ↑↓ Hold (hold last value, select hold time), 3.8mA, 21.0mA
	Pulse Out		
		Source	Select from list ↑↓ Off Channel 1, Channel 2 Math 1, Math 2 System, Test
		Units	Select from unit list ↑↓
		Mode	Select from list ↑↓ Alarm (select on point, off point) Pulse (select value, width) Linear (select min value, max value, damping)
	Relay Out		
		Source	Select from list ↑↓ Off Channel 1, Channel 2 Math 1, Math 2 System, Test
		Units	Select from unit list ↑↓
		Mode	Select from list ↑↓ Alarm (select on point, off point) Pulse (select value, width) Linear (select min value, max value, damping)
	PT100 4 WIRE		
		Source	Select from list ↑↓ Off Channel 1, Channel 2 Math 1, Math 2 System, Test
		Type	Select from list ↑↓ User (Fixed value - enter) PT100 (Measured - select whether inlet, outlet, compensation and enter offset if required)
	Current In		
		Source (channel)	Select from list ↑↓ Off, Channel 1, Channel 2, Math 1, Math 2 System, Test
		Source (value)	Select from list ↑↓ <i>Density, Viscosity, Temperature, Other</i>
			<i>Minimum, Maximum, Span settings as on outputs</i>
	Other In/Out types		Refer to Technical Support
System			
	Instrument info		
		Model Code	210
		Serial No.	<i>Example: 21000013</i>
		HW Revision	<i>Example: 3.00, 1.60</i>
		SW Revision	<i>Example: 4.22-0000, 4.00</i>
	Calculation		
		Low F Cut	± <i>Low flow velocity cut off</i> 0 ... 1 m/s
		Max F Cut	± <i>Maximum flow velocity cut off</i>

			0 ... 30 m/s
		Corrected	Apply flow velocity profile correction Yes No
		PV Offset	Calibration process variable zero offset -30 ... 30 m/s
		PV Scaling	Calibration process variable gradient scaling 0.0010 ... 10 units (based on flow velocity)
		Zero Cal	Zero calibration settings
		Zero	Perform auto zero calibration Yes No
		Track	Track zero offset Yes No
		Delta	Zero flow delta time offset in ns, read from sensor PROM or entered directly for special sensors
		Timeup	Upstream transit-time offset in μ s, allows for fixed delays in special sensors, buffer rods and extension leads
		Heat Capacity	Specific heat capacity of medium
	User		
		Identifier	Example: Pump P3A 9 character string
		Tag No.	Example: 1FT-3011 9 character string
		Password	4 digit code
	Test		
		Installation	Control system simulation: A cyclic repetition of increasing flow velocity across the measureable range. All configured outputs respond as if this was a measured change in flow. Yes, No
		Display	Display screen test routine
		Keypad	Keypad test routine
		Memory	Memory test routine, Memory erase yes/no
		Peripherals	Unit temperature, time, date, clock, battery meter, charger test routine
		Ultrasonics	Tests ultrasonic board and sensors
	Settings		
		Date	Example: 03/10/07
		Time	Example: 09:27:00
		Date Format	Select from list $\uparrow\downarrow$ dd/mm/yy mm/dd/yy yy/mm/dd
		Language	Select from list $\uparrow\downarrow$ As installed
		Keypad	Enable keypad sound Yes No
		Battery	Battery Low Warn. (yes / no) Auto off timer (1...59 min) Battery full (sets coulomb counting to show a full battery eg. when battery has been charged externally) Saver Mode (yes / no)
	Defaults		Reload factory default settings, except for date and time Yes

			No
	Key Lock		When next in Measurement Mode, the Password will need to be entered to exit to the menu. Yes No
Diagnostics			
		Temperature	Shows control unit temperature
		Log Memory	Percentage of unused datalogger memory, estimated time remaining
		Battery	Battery charge level (percentage)
		Volts	Battery voltage
		Capacity	Remaining battery capacity (mAh)
Datalogger			
		Interval	A value of zero turns the datalogger off, a non-zero value turns the datalogger on and defines the logging interval. 0 ... 999 s
		Selection	Select up to 10 items from list ↑↓ ENTER to select, 0 to remove Available items as in list for display / output
		Low Memory	Warning output: The amount of memory remaining at which the flowmeter begins to give an audible warning. 4 ... 100 %
		Log Download	Sends logger content to serial communication port.
		Log Erase	Erase datalogger Yes / no
Serial Comms			
		Mode	Select from list ↑↓ None Printer, Diagnostic, Log download, Calibration Test (not normally used by user)
		Baud	Select from list ↑↓ 9600, 19200, 57600, 115200
		Parity	Select from list ↑↓ None Even (Default) Odd

Table 5: Firmware menu structure

5.2 Diagnostics

Diagnostic screens can be viewed directly during measurement using the **3/DISP** and **1/NEXT** keys, or through the menu structure.

5.3 Display settings

Customer specific settings for data to be displayed can be achieved using the appropriate menu items to select units for the top, middle and bottom lines.

5.3.1 Main PV

The main Process Value (PV) is the primary measurement data, and is usually displayed as the Middle Units.

5.4 Output configuration

There are two output connectors on the IFX-P210. One is for serial communication, the other provides process inputs and outputs using connecting wires and/or a junction box.

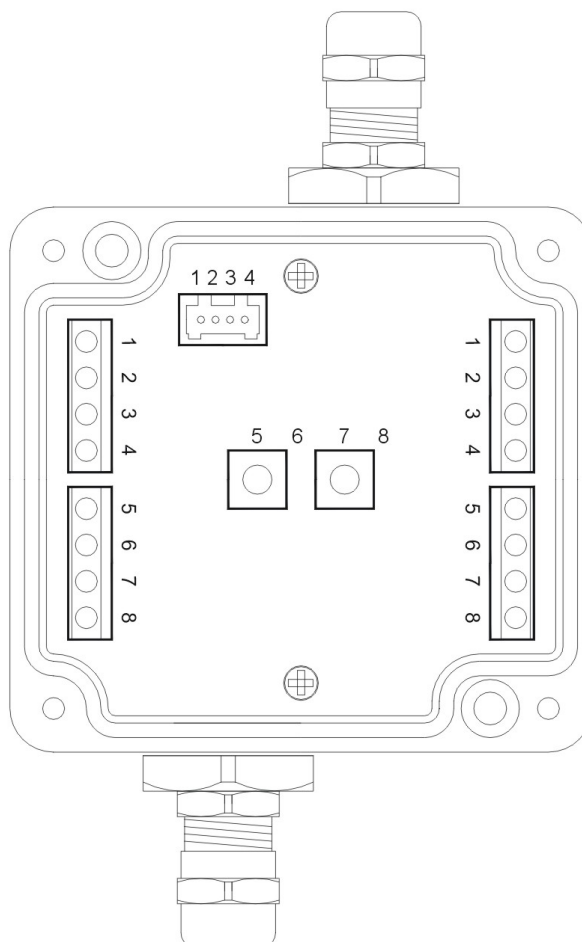

Illustration 9: Process output junction box

Serial interface

5.4.1 Serial interface

The serial interface can be used to transmit data on-line or to download the integral datalogger content. The settings can be found in the **Serial Comms** submenu.

5.5 Inputs/Outputs



5.5.1 Modbus RTU

An RS 485 interface is used for networking up to 32 flowmeters to a centralised computer system. Each flowmeter is given an unique address to be able to communicate effectively. The communication protocol used conforms to the conventions of the Modbus RTU protocol, a description of which is

given in a separate document. Please refer to customer support for further information.

Wiring	
Setup	Please refer to customer support.
Operation	Please refer to customer support.

5.5.2 HART compatible output



The IFX-P210 can also be configured with an optional module which responds to output commands conforming to the HART protocol. Please refer to customer support for further information.

HART® is a registered trademark of the HART Communication Foundation.

Wiring	
Setup	Please refer to customer support.
Operation	Please refer to customer support.

Analogue outputs

5.5.3 Analogue current output 0/4 ... 20 mA

The analogue current outputs operate in a 4 ... 20 mA or 0 ... 20 mA span.



Current outputs may be assigned to process values in the “mode” section of the output menu. The outputs can be programmed and scaled within the menu structure.

Wiring	
Electrical characteristics	<p>0/4...20 mA active and 4...20 mA passive options. Galvanically isolated from main electronics and from other I/O's. Passive: U=9...30 V, RLoad=50 ohm typical. Resolution: 16 bit, accuracy: 0.1 % of MV. Active: RLoad<500 ohm, U=30 V. Resolution: 16 bit, accuracy: 0.1 % of MV.</p>

5.5.4 Analogue voltage output 0 – 10 v

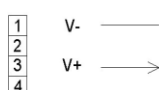

Voltage outputs may be assigned to process values in the “mode” section of the output menu. The outputs can be programmed and scaled within the menu structure.

Wiring	<p style="text-align: center;">Volts out (optional)</p> 
Electrical characteristics	<p>Galvanically isolated from main electronics and from other I/O's. Range 0...10 V. RLoad=1000 ohm. Resolution: 16 bit, accuracy: 0.1% of MV.</p>

5.5.5 Analogue frequency output (passive)

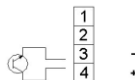

Frequency outputs may be assigned to process values in the “mode” section of the output menu. The outputs can be programmed and scaled within the menu structure.

Wiring	<p style="text-align: center;">Frequency (analogue output) (optional)</p> 
Electrical characteristics	<p>Galvanically isolated from main electronics and from other I/O's. Open-collector: 2...10000 Hz. U=24 V, I_{max}=4 mA.</p>

Digital outputs

5.5.6 Digital open collector output

Open-Collector outputs may be assigned to process values in the “mode” section of the output menu. The outputs are configured using the menu structure.

The totaliser function is enabled and controlled using the menu structure



Wiring	<p style="text-align: center;">Optically switched relay "Open-Collector" (optional)</p> 
Electrical characteristics	<p>Galvanically isolated from main electronics and from other I/O's. Totaliser pulse, value 0.01...1000/unit. Active high and active low available. Width 1...990 ms. U=24 V, I_{max}=4 mA.</p>

5.5.7 Digital relay output

Relay outputs may be assigned to process values in the “mode” section of the output menu. The relay outputs are configured using the menu structure.



Wiring	
Electrical characteristics	<p>Form A (SPDT-NO and NC) contacts Width 3...990 ms. U=48 V, I_{max}=250 mA. Galvanically isolated from main electronics and from other I/O's. Mode: Alarm, fault, totaliser (programmable). 1 Form A (SPST-NO) contacts. 1 Form A (SPST-NC) contacts. Width 3...990 ms. U=48 V, I_{max}=250 mA.</p>

Inputs

5.5.8 Analogue current input 0/4 ... 20 mA

 Wiring	<p>Analogue input (optional)</p> <p>Analogue input (optional)</p>
Electrical characteristics	<p>Active (top) or passive (bottom) variants Measuring range active = 0 ... 20 mA at 30 V Measuring range passive = 4 ... 20 mA Accuracy = 0.1 % of measured value</p>

5.6 Sound velocity measurement (SVM)

The measured sound velocity (SOS) is available as a diagnostic function during measurement and may be applied to a Process Output by selecting "C" from the appropriate output menu.

5.7 Wall thickness measurement (WTM)

Optional sensor probes to measure pipe wall thickness are available. The IFX-P210 will recognise a connected probe when entering the Setup or WTM Wizards, the measurement mode or the Scope function. Use the Setup Wizard or Installation menu to set the pipe material. Select "Start Measurement". The IFX-P210 will recognise the probe and display the measurement screen. Wall thickness will be shown when the sensor is in good acoustic contact with the pipe.

5.7.1 Wall Thickness Gauge (WTG) Wizard

To confirm pipe thickness and sound speed, select the "WTG Wizard" from the "Quick Start" menu. Enter the approximate expected thickness as "Reference THK" and select "Calibrate".

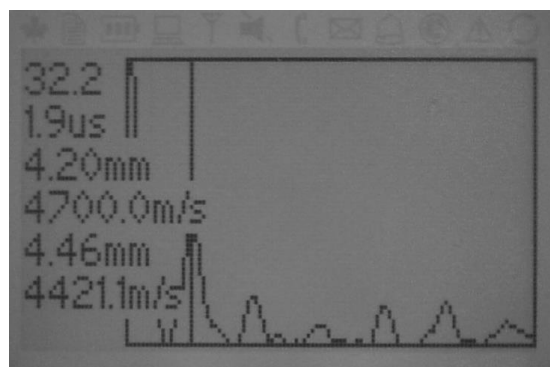

The screen displays the received acoustic pulse and values for the signal strength, the transit time, the reference thickness, the expected sound speed, the measured thickness at the reference sound speed and the measured sound speed at the reference thickness (top to bottom).

On leaving this screen using the <ESC> key, the flowmeter will ask if you wish to store the recorded value of longitudinal sound speed ("L-Speed" in the Pipe Menu).

5.8 Scope function

Isoil Industria flowmeters have an additional scope function which shows a representation of the pulse received by the sensors on Channel 1.

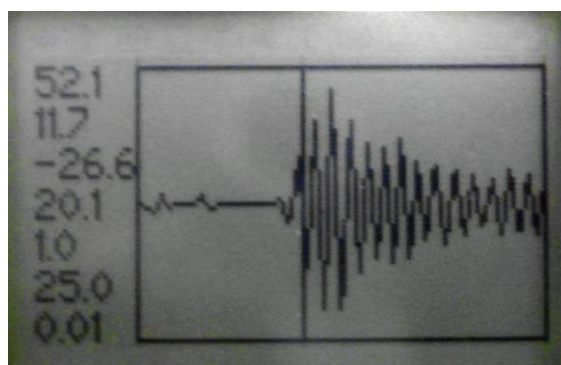

In addition to displaying the received pulse, this screen lists the following data (from top to bottom) :

Gain (dB)
Signal (dB)
Noise (dB)
Transit time (us)
Delta (ns) - [time downstream minus time upstream]
Control unit temperature (degC)
Flow (m/s)

6 Maintenance

IFX-P flowmeters are maintenance free concerning the flow measurement functions. Within the scope of periodic inspections, regular inspection for signs of damage or corrosion is recommended for the transducers, the junction box if installed, and the flowmeter housing.

6.1 Service/Repair

IFX-P flowmeters have been carefully manufactured and tested. If installed and operated in accordance with the operating instructions, no problems are usually experienced.



Should you nevertheless need to return a device for inspection or repair, please pay attention to the following points:

- Due to statutory regulations on environmental protection and safeguarding the health and safety of our personnel, the manufacturer may only handle, test and repair returned devices that have been in contact with products without risk to personnel and environment.
- This means that the manufacturer can only service this device if it is accompanied by a Return Material Authorization (RMA) confirming that the device is safe to handle.



If the device has been operated with toxic, caustic, flammable or water-endangering products, you are kindly requested:

- to check and ensure, if necessary by rinsing or neutralising, that all cavities are free from such dangerous substances,

7 Troubleshooting

Should there be the need to call customer service, please let us know the following details:



- Model code
- Serial number
- SW, HW revision
- Error log list

Possible error messages may include the following:

Error list

Error message	Group	Description	Error handling
USB INIT FAIL	Hardware	Internal board communication error	Power on/off, otherwise call customer support
NO SERIAL NO.	Hardware	Failed to read from FRAM	Call customer support
NO VERSION NO.	Hardware	Failed to read from FRAM	Call customer support
PARA READ FAIL	Hardware	Failed to read from FRAM	Load defaults, otherwise call customer support
PARA WRITE FAIL	Hardware	Failed to write to FRAM	Load defaults, otherwise call customer support
VAR READ FAIL	Hardware	Failed to read from FRAM	Call customer support

Table 6: Error messages

VAR WRITE FAIL	Hardware	Failed to write to FRAM	Call customer support
SYSTEM ERROR	Hardware		Call customer support
VISIBILITY ERR	Hardware	Failed to read from FRAM	Call customer support
FRAM LONG WRITE ERR	Hardware	Failed to write to FRAM	Call customer support
FRAM READ ERR	Hardware	Failed to read from FRAM	Call customer support
RTC ERR	Hardware	Real Time Clock failure	Power on/off, otherwise call customer support
EXTMEM ERR	Hardware	Logger memory failure	Power on/off, otherwise call customer support
SPI ERR	Hardware	SPI bus failure	Power on/off, otherwise call customer support
I2C ERR	Hardware	I2C bus failure	Power on/off, otherwise call customer support
MATH ERR	Software	Internal calculation error	Call customer support
STACK ERR	Software	Internal calculation error	Call customer support
ADDR ERR	Software	Internal calculation error	Call customer support
OSC ERR	Software	Internal calculation error	Call customer support
ADC ERR	Software	Internal calculation error	Call customer support
IO ERR	Software	Internal calculation error	Call customer support
TIMING ERR	Software	Internal calculation error	Call customer support
COMM INIT ERR	Hardware	Internal communication error	Power on/off, otherwise call customer support
COMM START ERR	Hardware	Internal communication error	Power on/off, otherwise call customer support
COMM HS0 ERR	Hardware	Internal communication error	Power on/off, otherwise call customer support
COMM HS1 ERR	Hardware	Internal communication error	Power on/off, otherwise call customer support
COMM READ AVE ERR	Hardware	Internal communication error	Power on/off, otherwise call customer support
COMM READ RAW ERR	Hardware	Internal communication error	Power on/off, otherwise call customer support
COMM READ HISTORY ERR	Hardware	Internal communication error	Power on/off, otherwise call customer support
COMM CRC ERR	Hardware	Internal communication error	Power on/off, otherwise call customer support
SENSOR COUPLING ERR	Application	Weak sensor coupling, low SNR	Recouple sensors, check installation, reduce number of passes, look for other location, then have a cup of tea and call customer support!

7.1 Data download difficulties

If difficulties are encountered downloading the logger data : -

- Check that the flowmeter is switched on and not in measurement mode.
- Check that the same number COM port is allocated in the “Device Manager” (or equivalent) as is set in the Isoflux+ software.
- Check that the settings (baud, parity, word length, stop bits) are identical.
- Use the supplied connectors – whether connecting to a 9-pin COM port or converting from serial communication to a Universal Serial Bus (USB).
- Is the logger in "Wrap" mode? If "yes", use a terminal program and the "Log download" command. If "No", Isoflux+ software may also be used.

8 Technical data

Material	Sound Speed* Shear Wave (at 25 °C)	
	m/s	ft/s
Steel, 1% Carbon, hardened	3,150	10,335
Carbon Steel	3,230	10,598
Mild Steel	3,235	10,614
Steel, 1% Carbon	3,220	10,565
302 Stainless Steel	3,120	10,236
303 Stainless Steel	3,120	10,236
304 Stainless Steel	3,141	10,306
304L Stainless Steel	3,070	10,073
316 Stainless Steel	3,272	10,735
347 Stainless Steel	3,095	10,512
"Duplex" stainless steel	2,791	9,479
Aluminium	3,100	10,171
Aluminium (rolled)	3,040	9,974
Copper	2,260	7,415
Copper (annealed)	2,325	7,628
Copper (rolled)	2,270	7,448
CuNi (70%Cu 30%Ni)	2,540	8,334
CuNi (90%Cu 10%Ni)	2,060	6,759
Brass (Naval)	2,120	6,923
Gold (hard-drawn)	1,200	3,937
Inconel	3,020	9,909
Iron (electrolytic)	3,240	10,630
Iron (Armco)	3,240	10,630
Ductile Iron	3,000	9,843
Cast Iron	2,500	8,203
Monel	2,720	8,924
Nickel	2,960	9,712
Tin (rolled)	1,670	5,479
Titanium	3,125	10,253
Tungsten (annealed)	2,890	9,482
Tungsten (drawn)	2,640	8,661
Tungsten carbide	3,980	13,058
Zinc (rolled)	2,440	8,005
Glass (pyrex)	3,280	10,761
Glass (heavy silicate flint)	2,380	7,808
Glass (light borate crown)	2,840	9,318
Nylon	1,150	3,772
Nylon, 6-6	1,070	3,510
Polyethylene (LD)	540	1,772
PVC, CPVC	1,060	3,477
Acrylic resin	1,430	4,690
PTFE	2,200	7,218

* Please note these values are to be considered nominal. Solids may be inhomogeneous and anisotropic. Actual values depend on exact composition, temperature, and to a lesser extent, on pressure and stress.

All data given at 25 °C (77 °F) unless otherwise stated

Substance	Chemical Formula	Specific Gravity	Sound Speed		Change Kinematic Viscosity v/°C		
			m/s	ft/s	m/s/°C	mm ² /s	x10 ⁻⁶ ft ² /s
Acetic anhydride	(CH ₃ CO) ₂ O	1.082 (20 °C)	1,180	3,871.4	2.5	0.769	8.274
Acetic acid, anhydride	(CH ₃ CO) ₂ O	1.082 (20 °C)	1,180	3,871.4	2.5	0.769	8.274
Acetic acid, nitrile	C ₂ H ₃ N	0.783	1,290	4,232.3	4.1	0.441	4.745
Acetic acid, ethyl ester	C ₄ H ₈ O ₂	0.901	1,085	3,559.7	4.4	0.467	5.025
Acetic acid, methyl ester	C ₃ H ₆ O ₂	0.934	1,211	3,973.1		0.407	4.379
Acetone	C ₃ H ₆ O	0.791	1,174	3,851.7	4.5	0.399	4.293
Acetylene dichloride	C ₂ H ₂ Cl ₂	1.26	1,015	3,330.1	3.8	0.400	4.304
Alcohol	C ₂ H ₆ O	0.789	1,207	3,960	4.0	1.396	15.02
Ammonia	NH ₃	0.771	1,729 33 °C)	(- 5,672.6 (-27 °C)	6.68	0.292 (-33 °C)	3.141 (-27 °F)
Benzene	C ₆ H ₆	0.879	1,306	4,284.8	4.65	0.711	7.65
Benzol	C ₆ H ₆	0.879	1,306	4,284.8	4.65	0.711	7.65
Bromine	Br ₂	2.928	889	2,916.7	3.0	0.323	3.475
n-Butane(2)	C ₄ H ₁₀	0.601 (0°C)	1,085 5° C)	(- 3,559.7 (23 °C)	5.8		
2-Butanol	C ₄ H ₁₀ O	0.81	1,240	4,068.2	3.3	3.239	34.851
sec-Butylalcohol	C ₄ H ₁₀ O	0.81	1,240	4,068.2	3.3	3.239	34.851
n-Butyl bromide (46)	C ₄ H ₉ Br	1.276 (20°C)	1,019 (20°C)	3,343.2 (68°F)		0.49 (15°C)	5.272 (59°C)
n-Butyl chloride (22,46)	C ₄ H ₉ Cl	0.887	1,140	3,740.2	4.57	0.529 (15°C)	5.692 (59°F)
Carbon tetrachloride	CCl ₄	1.595 (20°C)	926	3038.1	2.48	0.607	6.531
Carbon tetrafluoride (Freon 14)	CF ₄	1.75 (-150 °C)	875.2 150 °C)	(- 2,871.5 (-238 °F)	6.61		
Chloroform	CHCl ₃	1.489	979	3,211.9	3.4	0.55	5.918
Dichlorodifluoromethane (Freon 12)	CCl ₂ F ₂	1.516 (40 °C)	774.1	2,539.7	4.24		
Ethanol	C ₂ H ₆ O	0.789	1,207	3,960	4.0	1.39	14.956
Ethyl acetate	C ₄ H ₈ O ₂	0.901	1,085	3,559.7	4.4	0.489	5.263
Ethyl alcohol	C ₂ H ₆ O	0.789	1,207	3,960	4.0	1.396	15.020
Ethyl benzene	C ₈ H ₁₀	0.867 (20 °C)	1,338 (20 °C)	4,89.8 (68 °F)		0.797 (17 °C)	8.575 (63 °F)
Ether	C ₄ H ₁₀ O	0.713	985	3231.6	4.87	0.311	3.346
Ethyl ether	C ₄ H ₁₀ O	0.713	985	3231.6	4.87	0.311	3.346
Ethylene bromide	C ₂ H ₄ Br ₂	2.18	995	3264.4		0.79	8.5
Ethylene chloride	C ₂ H ₄ Cl ₂	1.253	1,193	3,914		0.61	6.563
Ethylene glycol	C ₂ H ₆ O ₂	1.113	1,658	5439.6	2.1	17,208 (20°C)	185.158 (68°F)
Fluorine	F	0.545 (-143 °C)	403 143 °C)	(- 1322.2 (-225 °F)	11.31		
Formaldehyde, methyl ester	C ₂ H ₄ O ₂	0.974	1,127	3697.5	4.02		
Freon R12			774.2	2540			
Glycol	C ₂ H ₆ O ₂	1.113	1658	5439.6	2.1		
50% Glycol/50% H ₂ O			1,578	5,177			
Isopropanol	C ₃ H ₈ O	0.785 (20 °C)	1,170 (20 °C)	3,838.6 (68 °F)		2.718	29.245
Isopropyl alcohol (46)	C ₃ H ₈ O	0.785 (20 °C)	1,170 (20 °C)	3,838.6 (68 °F)		2.718	29.245
Kerosene		0.81	1,324	4,343.8	3.6		

Methane	CH ₄	0.162 (-89 °C)	405 (-89 °C)	1,328.7 (-128 °F)	17.5		
Methanol	CH ₄ O	0.791 (20 °C)	1,076	3,530.2	292	0.695	7.478
Methyl acetate	C ₃ H ₆ O ₂	0.934	1,211	3,973.1		0.407	4.379
Methyl alcohol	CH ₄ O	0.791	1,076	3,530.2	292	0.695	7.478
Methyl benzene	C ₇ H ₈	0.867	1,328 (20 °C)	4,357 (68 °F)	4.27	0.644	7.144
Milk, homogenized			1,548	5,080			
Naphtha		0.76	1,225	4,019			
Natural Gas		0.316 (-103 °C)	753 (-103 °C)	2,470.5 (-153 °F)			
Nitrogen	N ₂	0.808 (-199 °C)	962 (-199 °C)	3,156.2 (-326 °F)		0.217 (-199 °C)	2.334 (-326 °F)
Oil, Car (SAE 20a.30)		1.74	870	2,854.3		190	2,045.093
Oil, Castor	C ₁₁ H ₁₀ O ₀	0.969	1,477	4,845.8	3.6	0.670	7.209
Oil, Diesel		0.80	1,250	4,101			
Oil, Fuel AA gravity		0.99	1,485	4,872	3.7		
Oil (Lubricating X200)			1,530	5,019.9			
Oil (Olive)		0.912	1,431	4,694.9	2.75	100	1,076.365
Oil (Peanut)		0.936	1,458	4,738.5			
Propane (-45 to -130 °C)	C ₃ H ₈	0.585 (-45 °C)	1,003 (45 °C)	-3,290.6 (-49 °F)	5.7		
1-Propanol	C ₃ H ₈ O	0.78 (20 °C)	1,222 (20 °C)	4,009.2 (68 °F)			
2-Propanol	C ₃ H ₈ O	0.785 (20 °C)	1,170 (20 °C)	3,838.6 (68 °F)		2.718	29.245
Propene	C ₃ H ₆	0.563 (-13 °C)	963 (13 °C)	-3,159.4 (9 °F)	6.32		
n-Propyl-alcohol	C ₃ H ₈ O	0.78 (20 °C)	1,222 (20 °C)	4,009.2 (68 °F)		2.549	27.427
Propylene	C ₃ H ₆	0.563 (-13 °C)	963 (-13 °C)	3,159.4 (9 °F)	6.32		
Refrigerant 11	CCl ₃ F	1.49	828.3 (0 °C)	2,717.5 (32 °F)	3.56		
Refrigerant 12	CCl ₂ F ₂	1.516 (-40 °C)	774.1 (40 °C)	-2,539.7 (-40 °C)	4.24		
Refrigerant 14	CF ₄	1.75 (-150 °C)	875.24 (150 °C)	-2,871.6 (-268 °F)	6.61		
Refrigerant 21	CHCl ₂ F	1.426 (0 °C)	891 (0 °C)	2,923.2 (32 °F)	3.97		
Refrigerant 22	CHClF ₂	1.491 (-69 °C)	893.9 (50 °C)	2,932.7 (122 °F)	4.79		
Refrigerant 113	CCl ₂ F-CClF ₂	1.563	783.7 (0 °C)	2,571.2 (32 °F)	3.44		
Refrigerant 114	CClF ₂ -CClF ₂	1.455	665.3 (10 °C)	-2,182.7 (14 °F)	3.73		
Refrigerant 115	C ₂ ClF ₅		656.4 (50 °C)	-2,153.5 (-58 °F)	4.42		
Refrigerant C318	C ₄ F ₈	1.62 (-20 °C)	574 (-10 °C)	1,883.2 (14 °F)	3.88		
Sodium nitrate	NoNO ₃	1.884 (336 °C)	1,763.3 (336 °C)	5,785.1 (637 °F)	0.74	1.37 (336 °C)	14.74 (637 °F)
Sodium nitrite	NoNO ₂	1.805 (292 °C)	1,876.8 (292 °C)	6,157.5 (558 °F)			
Sulphur	S		1,177 (250 °C)	3,861.5 (482 °F)	-1.13		
Sulphuric Acid	H ₂ SO ₄	1.841	1,257.6	4,126	1.43	11.16	120.081

Tetrachloroethane	C ₂ H ₂ Cl ₄	1553 (20 °C)	1,170 (20 °C)	3,838.6 (68 °F)		1.19	12.804
Tetrachloro-ethene	C ₂ Cl ₄	1.632	1,036	3,399			
Tetrachloro-Methane	CCl ₄	1.595 (20 °C)	926	3,038.1		0.607	6.531
Tetrafluoro-methane (Freon 14)	CF ₄	1.75 (-150 °C)	875.24 (-150 °C)	4,357 (68 °F)	-2,871.5 (-283 °F)	6.61	
Toluene	C ₇ H ₈	0.867 (20 °C)	1,328 (20 °C)	4,291.3	4.2	0.644	6.929
Toluol	C ₇ H ₈	0.866	1,308	4,291.3	4.2	0.58	6.24
Trichloro-fluoromethane (Freon 11)	CCl ₃ F	1.49	828.3 (0 °C)	2,717.5 (32 °F)	3.56		
Turpentine		0.88	1,255	4,117.5		1.4	15.064
Water, distilled	H ₂ O	0.996	1,498	4,914.7	-2.4	1.00	10.76
Water, heavy	D ₂ O		1,400	4,593			
Water, sea		1.025	1531	5023	-2.4	1.00	10.76

Temperature		Sound Speed in Water	
° C	° F	m/s	ft/s
0	32.0	1402	4600
1	33.8	1407	4616
2	35.6	1412	4633
3	37.4	1417	4649
4	39.2	1421	4662
5	41.0	1426	4679
6	42.8	1430	4692
7	44.6	1434	4705
8	46.4	1439	4721
9	48.2	1443	4734
10	50.0	1447	4748
11	51.8	1451	4761
12	53.6	1455	4774
13	55.4	1458	4784
14	57.2	1462	4797
15	59.0	1465	4807
16	60.8	1469	4820
17	62.6	1472	4830
18	64.4	1476	4843
19	66.2	1479	4853
20	68.0	1482	4862
21	69.8	1485	4872
22	71.6	1488	4882
23	73.4	1491	4892
24	75.2	1493	4899
25	77.0	1496	4908
26	78.8	1499	4918
27	80.6	1501	4925
28	82.4	1504	4935
29	84.2	1506	4941
30	86.0	1509	4951
31	87.8	1511	4958
32	89.6	1513	4964
33	91.4	1515	4971
34	93.2	1517	4977

35	95.0	1519	4984
36	96.8	1521	4984
37	98.6	1523	4990
38	100.4	1525	4997
39	102.2	1527	5010
40	104.0	1528	5013
41	105.8	1530	5020
42	107.6	1532	5026
43	109.4	1534	5033
44	111.2	1535	5036
45	113.0	1536	5040
46	114.8	1538	5046
47	116.6	1538	5049
48	118.4	1540	5053
49	120.2	1541	5056
50	122.0	1543	5063
51	123.8	1543	5063
52	125.6	1544	5066
53	127.4	1545	5069
54	129.2	1546	5072
55	131.0	1547	5076
56	132.8	1548	5079
57	134.6	1548	5079
58	136.4	1548	5079
59	138.2	1550	5086
60	140.0	1550	5086
61	141.8	1551	5089
62	143.6	1552	5092
63	145.4	1552	5092
64	147.2	1553	5092
65	149.0	1553	5095
66	150.8	1553	5095
67	152.6	1554	5099
68	154.4	1554	5099
69	156.2	1554	5099
70	158.0	1554	5099
71	159.8	1554	5099
72	161.6	1555	5102
73	163.4	1555	5102
74	165.2	1555	5102
75	167.0	1555	5102
76	167.0	1555	5102
77	170.6	1554	5099
78	172.4	1554	5099
79	174.2	1554	5099
80	176.0	1554	5099
81	177.8	1554	5099
82	179.6	1553	5095
83	181.4	1553	5095
84	183.2	1553	5095
85	185.0	1552	5092
86	186.8	1552	5092
87	188.6	1552	5092
88	190.4	1551	5089

89	192.2	1551	5089
90	194.0	1550	5086
91	195.8	1549	5082
92	197.6	1549	5082
93	199.4	1548	5079
94	201.2	1547	5076
95	203.0	1547	5076
96	204.8	1546	5072
97	206.6	1545	5069
98	208.4	1544	5066
99	210.2	1543	5063
100	212.0	1543	5063
104	220.0	1538	5046
110	230.0	1532	5026
116	240.0	1524	5000
121	250.0	1516	5007
127	260.0	1507	4944
132	270.0	1497	4912
138	280.0	1487	4879
143	290.0	1476	4843
149	300.0	1465	4807
154	310.0	1453	4767
160	320.0	1440	4725
166	330.0	1426	4679
171	340.0	1412	4633
177	350.0	1398	4587
182	360.0	1383	4538
188	370.0	1368	4488
193	380.0	1353	4439
199	390.0	1337	4387
204	400.0	1320	4331
210	410.0	1302	4272
216	420.0	1283	4210
221	430.0	1264	4147
227	440.0	1244	4082
232	450.0	1220	4003
238	460.0	1200	3937
243	470.0	1180	3872
249	480.0	1160	3806
254	490.0	1140	3740
260	500.0	1110	3642

Specific Heat Capacity

Medium	SHC (KJ/Kg.K)
Ethanol @ 0 deg C	2.30
Ethylene Glycol	2.36
Freon R12 @ 5 deg C	0.88
Light oil @ 15 deg C	1.80
Mineral Oil	1.67
Paraffin	2.13
Propane @ 0 deg C	2.40
Water	4.18
Water (salt)	3.93

9 Specification

General

Measuring principle : Ultrasonic time difference correlation principle
 Flow velocity range : 0.01 ... 25 m/s
 Resolution : 0.25 mm/s
 Repeatability : 0.15 % of measured value ± 0.015 m/s
 Accuracy : $\pm 1 \dots 3$ % of measured value depending on application,
 ± 0.5 % of measured value with process calibration
 Turn down ratio : 1/100
 Gaseous and solid content of liquid media : < 10 % of volume

Flowmeter

Enclosure : Portable
 Degree of protection : IP 67 according to EN 60529
 Operating temperature : -10 ... 60 °C (14 ... 140 °F)
 Housing material : Polypropylene copolymer
 Flow channels : 1 (standard), 2 (on request and subject to availability)
 Power supply : 1, 2 or 3 x LiFePo4 12.8 Ah
 Power adaptor 100 ... 240 V AC, 9 V DC output
 Operating time 1 battery pack – up to 7 days continuous operation
 30 days in saver mode
 2 battery packs – up to 14 days continuous operation
 60 days in saver mode
 3 battery packs – up to 21 days continuous operation
 100 days in saver mode
 (based on normal operating conditions, with no process outputs enabled)
 Display : LCD graphic display, 128 x 64 dots, backlit
 Dimensions : H 260 x W 280 x D 200 mm
 Weight : Approx. 6 kg
 Power consumption : < 5 W
 Measurement rate : 1Hz standard, (higher rates on application)
 Variable rate (seconds) and Saver Mode (minutes)
 Operating languages : English, 2 other (as requested and subject to availability)
 Response time : 1 s, faster rates upon request

Quantity and units of measurement

Volumetric flow rate : m³/h, m³/min, m³/s, l/h, l/min, l/s,
 USgal/h (US gallons per hour), USgal/min, USgal/s,
 bbl/d (barrels per day), bbl/h, bbl/min, bbl/s
 Flow velocity : m/s, ft/s, inch/s
 Mass flow rate : g/s, t/h, kg/h, kg/min
 Volume : cubic metres, l, gal (US gallons), bbl
 Mass : g, kg, t
 Heat flow : W, kW, MW (with heat quantity measurement option)
 Heat quantity : J, kJ, kWh (with heat quantity measurement option)
 Temperature : Deg C (with heat quantity measurement or temperature compensation)

C m/s (measured sound speed), CU (housing temperature), K (correction factor),
 REY (Reynolds number), V (battery voltage)
 SOS, DEN, KIN, DYN, SHC (sound speed, density, kinematic viscosity, dynamic viscosity,
 Specific Heat Capacity from inputs/calculation),
 TEMP (specified or measured fluid temperature),
 PRESS (specified or measured fluid pressure),
 Tin, Tout (inlet and outlet temperature)

Internal data logger

Storage capacity : In excess of 1 million data points (16MB)
 Logging data : Up to ten selected variables

Communication

Serial interface : Universal Serial Bus (USB)
 Data : Instantaneous measured value, parameter set and configuration, logged data

Isoflux+ Software

Functionality : Downloading of measured values/parameter sets, graphical presentation, list format, export to third party software, on-line transfer of measured data
Operating systems : Windows 2000, NT, XP, Vista, 7, 8, 10; Linux; Mac (optional)

Process inputs

: Galvanically isolated from main electronics and from other I/O's
Temperature : PT 100, four-wire circuit, measuring range - 50 ... 400 °C, resolution 0.1K, accuracy ± 0.2 K

Process outputs

: Galvanically isolated from main electronics and from other I/O's
Current : 0/4 ... 20 mA, active ($R_{Load} < 500$ Ohm), 16 bit resolution, U = 30 V, accuracy = 0.1 %
Voltage : 0 ... 10 V, $R_i = 500$ Ohm
Digital (Optical Open Collector) : U = 24 V, $I_{max} = 4$ mA
Digital (relay) : Form C (SPDT-CO) contacts, U = 48 V, $I_{max} = 250$ mA

Other outputs available on request.

Clamp-on sensors**K1N**

Diameter range : 25 ... 2500 mm
Dimensions : 60 x 30 x 34 mm
Material : Stainless steel
Temperature range : -30 ... 130 °C (-22 ... 266 °F)
Degree of protection : IP 68 (1.5m) according to EN 60529
Cable length : 4.0m

10 CE Declaration of Conformity

EU Declaration of Conformity (DoC)

We/Noi

Company name/Azienda:

Postal address/Indirizzo:

Postcode and City/Cap e Città:

Telephone number/Telefono:

E-Mail address:

ISOIL Industria spa
via f.lli Gracchi, 27
20092 Cinisello Balsamo (MI) - Italy
+39-02-660271
isomagservice@isoil.it

declare under our sole responsibility that the products listed below: /dichiariamo sotto la nostra responsabilità che i seguenti prodotti:

Product model/Modello:

Ultrasonic flowmeter/Misuratore di portata ad ultrasuoni: Isoflux IFX-F100, IFX-P200, IFX-P210 and associated trasducers/ e i trasduttori associati

are in conformity with the EEC directives /sono conformi alle seguenti direttive europee:

(1) ElectroMagnetic Compatibility Directive (EMC) 2014/30/EU

(2) Low Voltage Directive (LVD) 2014/35/EU

are in conformity with the following European Standards / sono conformi con i seguenti standard comunitari:

<i>Class/Classe</i>	<i>Standard</i>	<i>Description/Descrizione</i>
<u>EMC Directive</u>	BS EN 61326-1:2013	Electrical equipment for measurement, control and laboratory use - EMC requirements / Apparecchi elettrici di misura, controllo e laboratorio - Prescrizioni di compatibilità elettromagnetica
<u>Immunity / Immunità</u>	BS EN 61326-1:2013 BS EN 61000-4-2:2009 BS EN 61000-4-3:2006 BS EN 61000-4-4:2012 BS EN 61000-4-5:2014 BS EN 61000-4-6:2014 BS EN 61000-4-11:2004	Electrical equipment for continuous unattended use / Apparecchiature elettriche per solo uso continuo incustodito Electrostatic discharge / Scariche elettrostatiche RF field / Campo RF Electric fast transient/burst / Transitori elettrici veloci / burst Surge / Sovratensioni RF conducted / RF condotta AC mains voltage dips and interruption / Alimnetazione in c.a., cadute di tensione e interruzioni
<u>Emission/ Emissioni</u>	BS EN 61326-1:2013 BS EN 55022:2010	Electrical equipment Class B / Apparecchiature elettriche Classe B Disturbance voltage Class B / Grandezza di disturbo Classe B
<u>Low Voltage Directive / Direttiva bassa tensione</u>	BS EN 61010-1:2010	Safety requirements for electrical equipment for measurement, control and laboratory use / Requisiti di sicurezza per apparecchi elettrici di misura, controllo e per utilizzo in laboratorio

Signed for and on behalf of/Firmato in nome e per conto di:

15/06/2016



Dr. R. Guazzoni
Legal representative

For EU Customers only - WEEE Marking.

Marking of electrical and electronic equipment in accordance with Directive 2012/19/EU



This symbol on the product indicates that it will not be treated as household waste. It must be handed over to the applicable take-back scheme for the recycling of electrical and electronic equipment. For more detailed information about the recycling of this product, please contact your local municipal office.

ISOIL INDUSTRIA S.p.A.

HEAD OFFICE	SERVICE
Via Fratelli Gracchi, 27 20092 Cinisello Balsamo (MI) Tel +39 02 66027.1 Fax 039 026123202 sales@isoil.it	isomagservice@isoil.it

If you want to find the complete list of our distributors access at the following link:

http://isoil.com/u_vendita.asp

BEFORE returning any material, please contact our SERVICE at the e-mail address:

isomagservice@isoil.com



The manufacturer guarantees only English text available on our web site www.isoil.com

Due to the constant technical development of its products, the manufacturer reserves the right to make changes and/or modify the information contained in this document without notice.